



Head office address: 241 Bradwick Drive, Concord, Ontario, Canada L4K 1K5

Mailing address: P.O. Box 90, Concord, Ontario, Canada L4K 1B2

Tel: (905) 660-6450 Toll free: 1-800-872-1968 Fax: (905) 660-6435 E-mail: info@dcl-inc.com Website: www.dcl-inc.com

MINE-X SOOTFILTER® LT DIMENSIONS

	DLT1	DLT2	DLT2.9	DLT3	DLT4	DLT4.9	DLT5	DLT5.5	DLT6	DLT7
Max. Engine Power* hp (kW)	45 (34)	98 (74)	165 (124)	165 (124)	226 (170)	262 (195)	276 (207)	315 (235)	494 (371)	845 (634)
Max. Exhaust Gas Flow cfm (m³/h)**	248 (422)	540 (917)	910 (1546)	910 (1546)	1246 (2118)	1444 (2454)	1522 (2586)	1737 (2951)	2723 (4627)	4659 (7916)
Approximate Weight lb(kg)	15 (6.8)	20 (9.1)	47 (21.4)	45 (20.4)	62 (28.1)	74 (33.6)	74 (33.6)	87 (39.5)	116 (52.6)	214 (97.1)
A – Filter Diameter in (mm)	6.09 (155)	7.93 (201)	9.93 (252)	9.43 (240)	10.93 (278)	11.68 (297)	11.68 (297)	12.43 (316)	15.43 (392)	20.43 (519)
B – Filter Centre Body Length in (mm)	11.19 (284)	13.98 (355)	19.44 (494)	21.92 (557)	21.92 (557)	21.91 (557)	23.92 (608)	24.93 (633)	24.93 (633)	24.75 (629)
C – Length Clamp – Clamp in (mm)	12.30 (312)	18.08 (459)	26.13 (663)	28.87 (733)	29.81 (757)	30.41 (773)	32.50 (826)	33.43 (849)	32.68 (830)	35.57 (903)
D – Overall Length in (mm)	19.04 (484)	26.33 (669)	34.47 (876)	37.11 (943)	38.05 (966)	38.76 (985)	40.74 (1035)	41.78 (1061)	40.92 (1039)	43.82 (1113)
E – Inlet Diameter in (mm)	CUSTOMER SPECIFIED									
F – Outlet Diameter in (mm)										

*MINE-X SOOTFILTER® operate on equipment with diesel engines which meet the minimal heat requirements for self-regeneration. This chart is for reference use only. Contact DCL for final DPF size determination.

** At 400°C

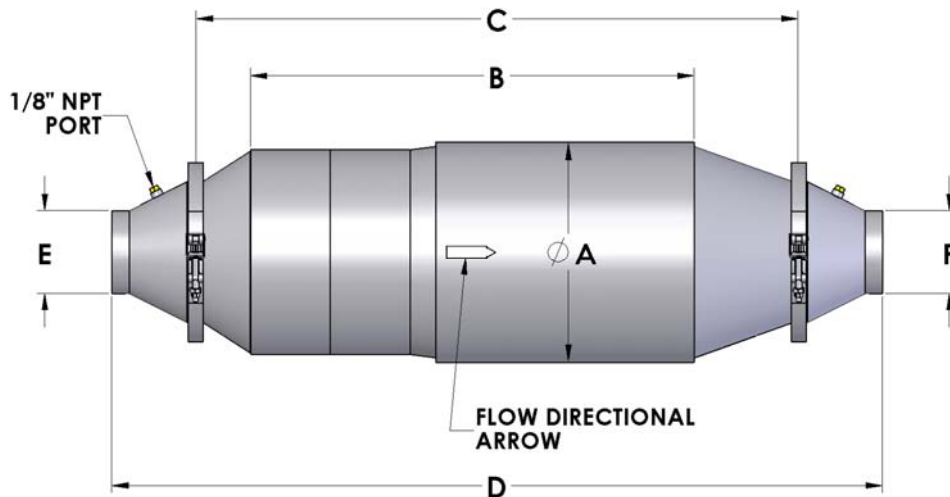

**DCL's policy is that of continuous product improvement.
DCL reserves the right to change any information without notice.**